

TREE ASSEMBLY INSTRUCTIONS

- Congratulations on purchasing your new tree from **Polygroup®**! This tree comes with Fast Shape™ technology which takes less than 10 minutes to set up and light up! Carefully follow the instructions below on how to assemble your new tree quickly and at ease:
1. Choose an appropriate location near a wall outlet.
 2. Assemble the tree stand (**Fig. A**) and place on a level surface.

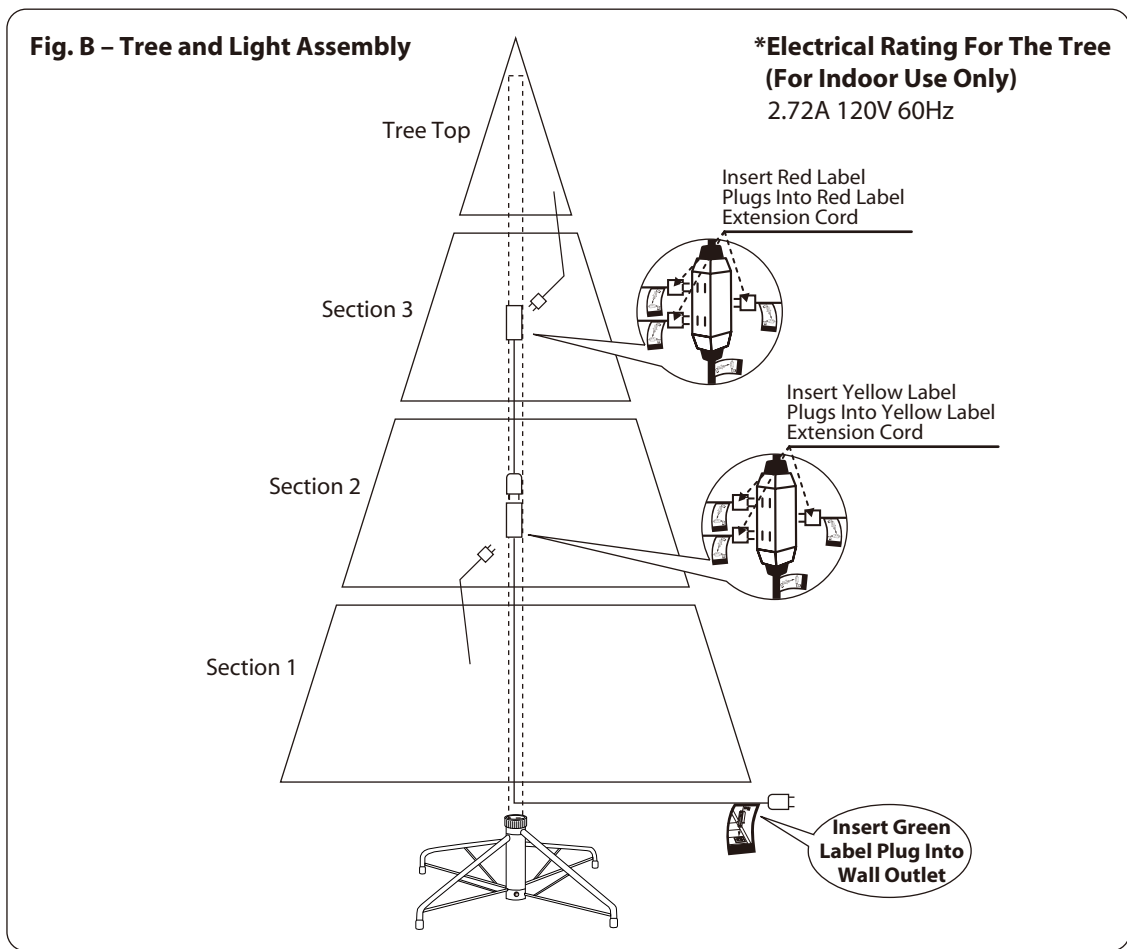
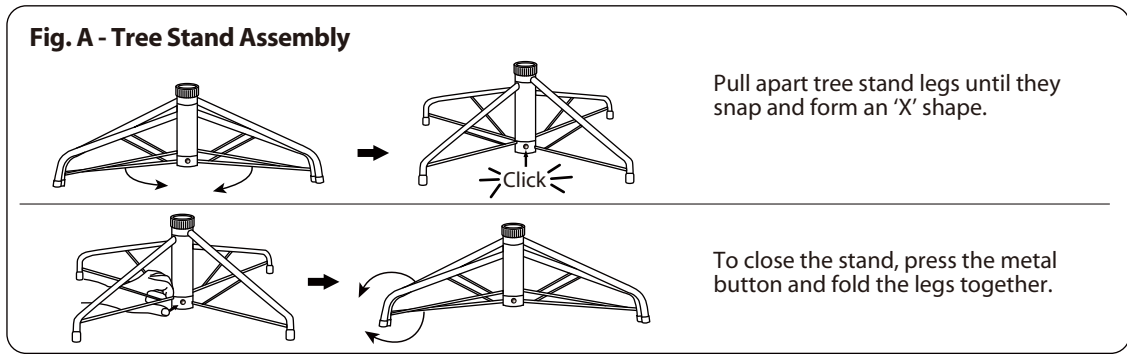

3. Each tree section is numbered with a sticker. Please identify all sections before assembling.
4. Assemble the tree from the bottom to the top. Insert the pole of Section 1 into the assembled stand. Insert the pole of Section 2 into Section 1. Insert the pole of the Section 3 into Section 2. Insert the pole of the tree top into Section 3. Ensure that all poles are firmly secure. Be sure that all wires are free of branch hinges.
5. Connect plugs to extension cords of the same color, and then insert green label plug into the wall outlet (**Fig. B**). Your entire tree should now be lit.
6. This tree is constructed with Fast Shape™ technology. Shaping is not necessary; you just need to slightly up-sweep all tips and shift branches to fill in any gaps for a fuller, uniform look. Your Christmas tree is now ready to be decorated.

STORAGE INSTRUCTIONS

1. Unplug from the wall outlet first, and disconnect other plugs. Then remove all ornaments and decorations.
2. Disassemble the tree from the top to the bottom. Gently lift the pole straight up to remove from the section below, and fold all branches toward the pole.
NOTE: In case of difficulty separating the poles, apply a small amount of lubricant at the joint, rotate the upper pole in both directions, and lift the upper pole again.
3. Carefully place all tree sections into the shipping box and tape it shut.
4. Store your tree in a cool, dry place away from sunlight. Exposure to excessive heat or humidity may damage your tree.
5. Keep out of reach of pets and children.

TROUBLESHOOTING TIPS

If The Tree Does Not Illuminate / Some Bulbs Do Not Light or Flicker

1. Check to make sure that all plugs and poles are properly and firmly connected as indicated in **Fig. B** and assembly instructions.
2. Disconnect from power source, then check for loose, broken or missing light bulbs and replace as needed.
3. Disconnect from power source, then check for blown fuses and replace as needed.
NOTE: Please make sure to use appropriate spare fuses as indicated on the label plug.

Loose Hinge Pin

1. Place the branch into the slot of bracket.
2. Insert a new hinge pin (included) through the hole, and secure using the retainer washer (**Fig. C**).

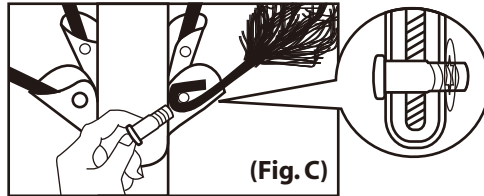

SPARE PARTS

This tree includes hinge pins/washers, and spare bulbs and fuses. If extra parts are needed, please contact our customer service center.

CUSTOMER SERVICE FOR CHRISTMAS TREES

For any questions, assistance or missing parts, **Do Not Return To Place Of Purchase.** Please contact us at 1-888-919-0070 or visit our website at www.polygroupstore.com. One of our customer service representatives will be happy to assist you.

Tree ID#: _____	Customer Name: _____
Tree UPC#: _____	Address (NO P.O. Boxes): _____
Store Purchased: _____	City & State: _____
Specify Problem: _____	Zip Code: _____
_____	Day Phone: _____
_____	Date Purchased: _____

TREE ID# IS LOCATED ON END PANEL OF BOX. TREE ID# IS REQUIRED WHEN REQUESTING REPLACEMENT PARTS.